

Features:

- 97dB sensitivity 1W/1m
- 1200 W Power handling
- 4" copper sandwich voice coil for low power compression
- Double treated cone for water protection
- Triple aluminium demodulating rings for ultra low distortio
- Optimal for high output subwoofers

SPECIFICATIONS

APPLICATION	Subwoofer	
Nominal impedance	Ohm	8
Power handling AES noise	W	1200
Sensitivity (1W/1m)	dB	97
Frequency response	Hz	35 - 2500
Voice coil diameter	mm	101.6 (4")
Voice coil material		Cu
Voice coil winding depth	mm	25
Magnet gab depth	mm	10
Basket		Cast Aluminium
Effect. diaphragm diameter D	mm	335

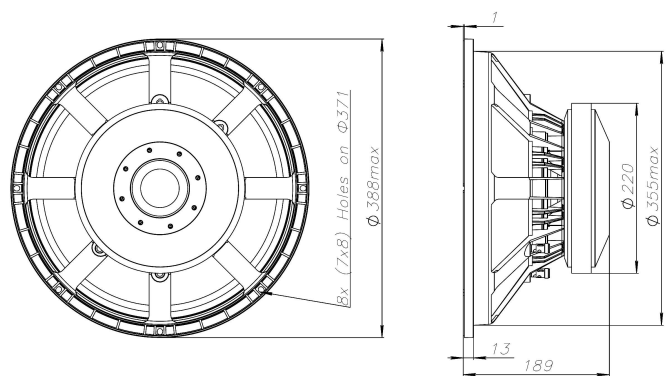

THILE - SMALL PARAMETERS			
Resonance frequency	Fs	Hz	39.8
DC resistance	Re	Ohm	5
Mechanical Q factor	Qms		6.60
Electrical Q factor	Qes		0.27
Total Quality factor	Qts		0.26
Equivalent volume	Vas	L	135
Moving mass	Mms	kg	0.132
Mechanical compl.	Cms	mm/N	0.12
BL factor	BL	Tesla m	24.96
Effective piston area	Sd	m ²	0.0897
Max. linear excursion	Xmax	mm	± 7.5
Voice coil inductance	Le1k	mH	0.73
	Le10k	mH	0.51

Frequency response measured 1000W (89.4V) at 1m in a closed enclosure of 100 litre incl. 2nd and 3rd harmonic distortion raised 10dB.

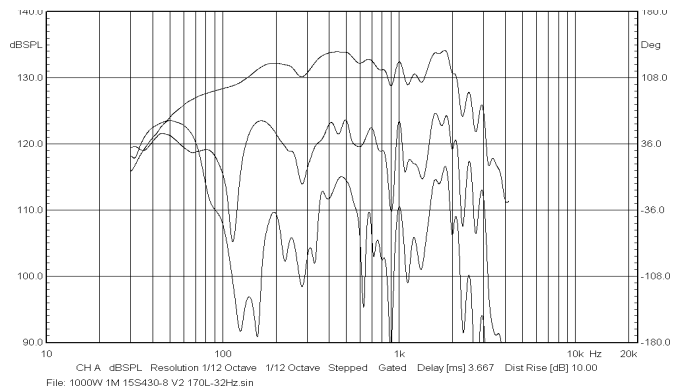

MOUNTING INFORMATION		
Overall diameter	mm	388
Mounting holes diameter	mm	7 x 8
Bolt circle diameter	mm	371
Baffle cut-out diameter	mm	358
Overall depth	mm	189
Net weight	kg	10.7

Recommended reflex enclosure:

80L/44Hz, BRD=190mm/402mm long

